

- (A) Zastavbovy rozmer / In-built dimension / Baumaße
- (B) Litinový odvod kouře / Cast iron spigot / Der gusseiserne Rauchabgang
- (C) Centralní privod vzduchu / Central air inlet / Zentralluftzufuhr
- (D) Primární a sekundární vzduch / Primary and secondary air / Primärluft und Sekundärluft
- (l) Volná plocha prosklení / Free glass area / Freie Glassichtfläche

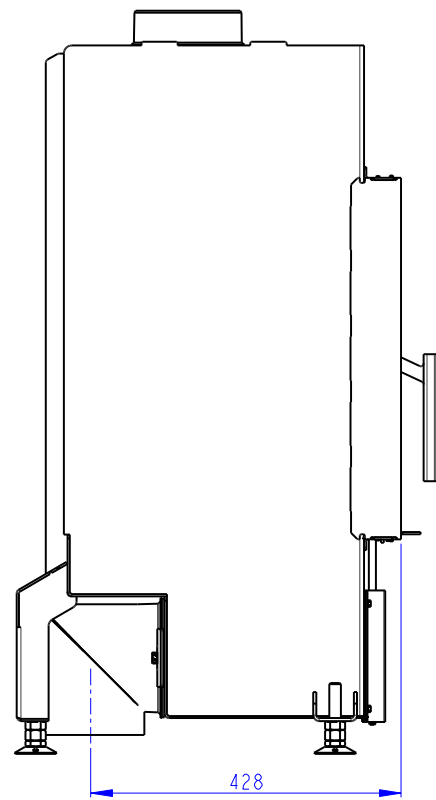

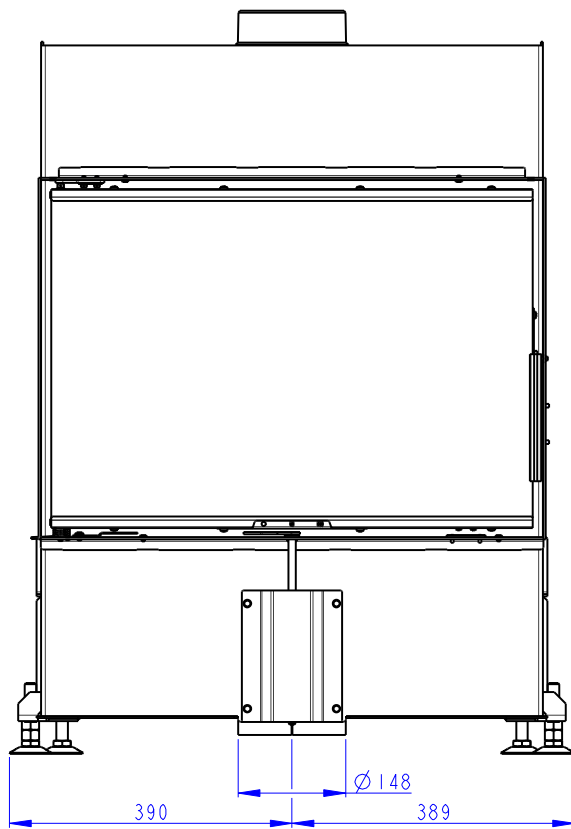

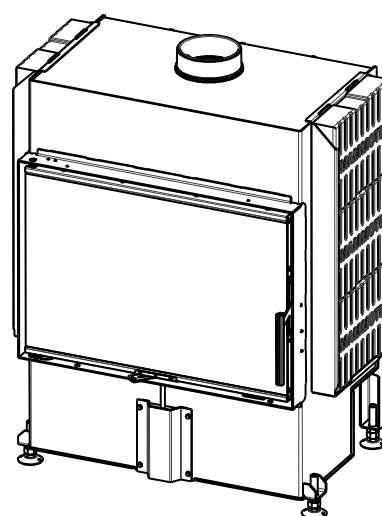

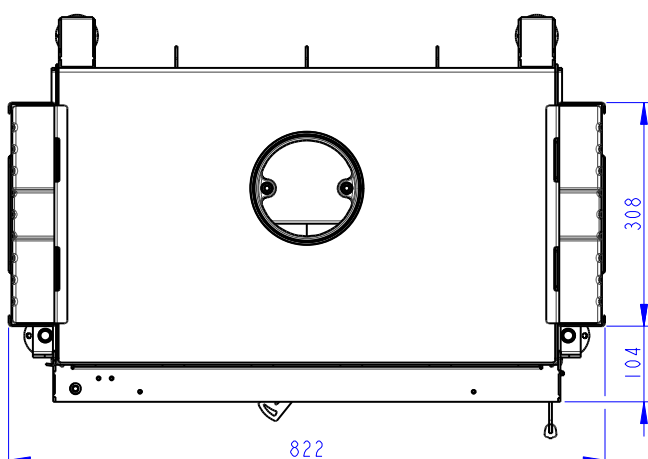
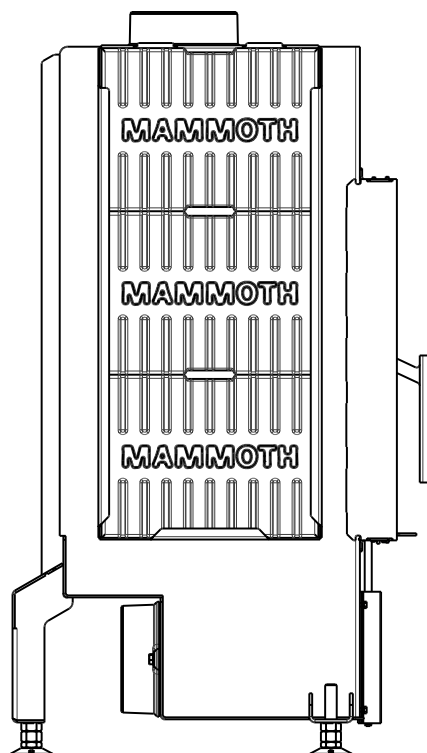
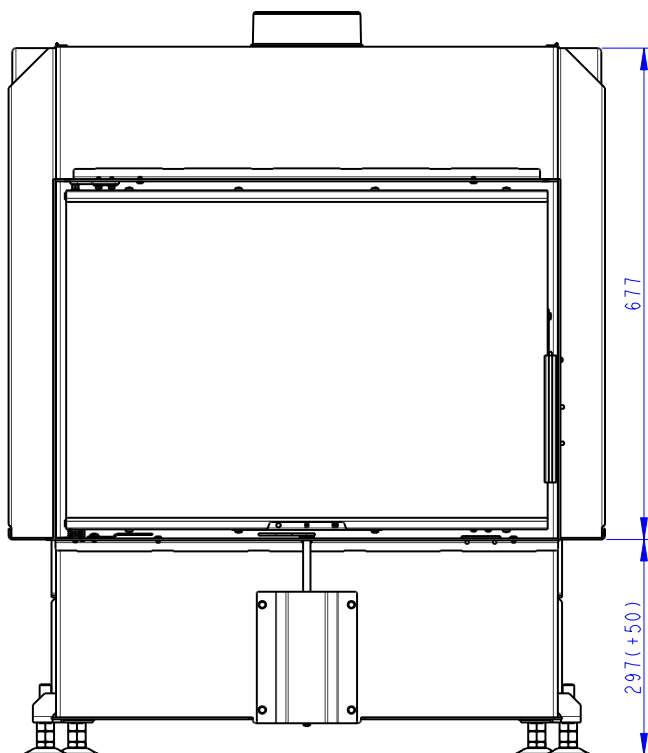
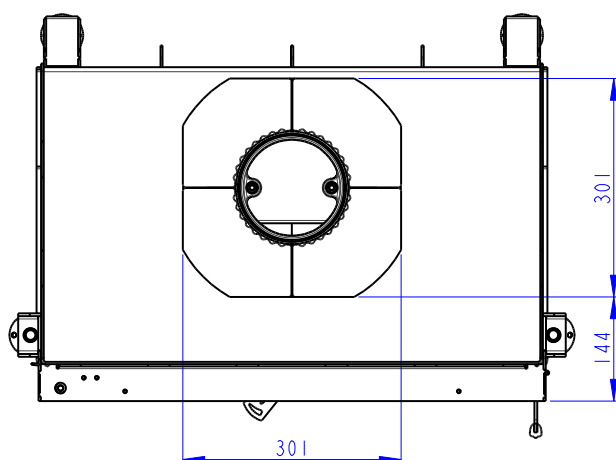
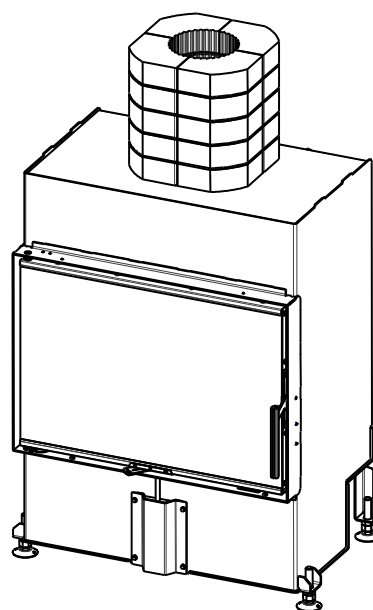
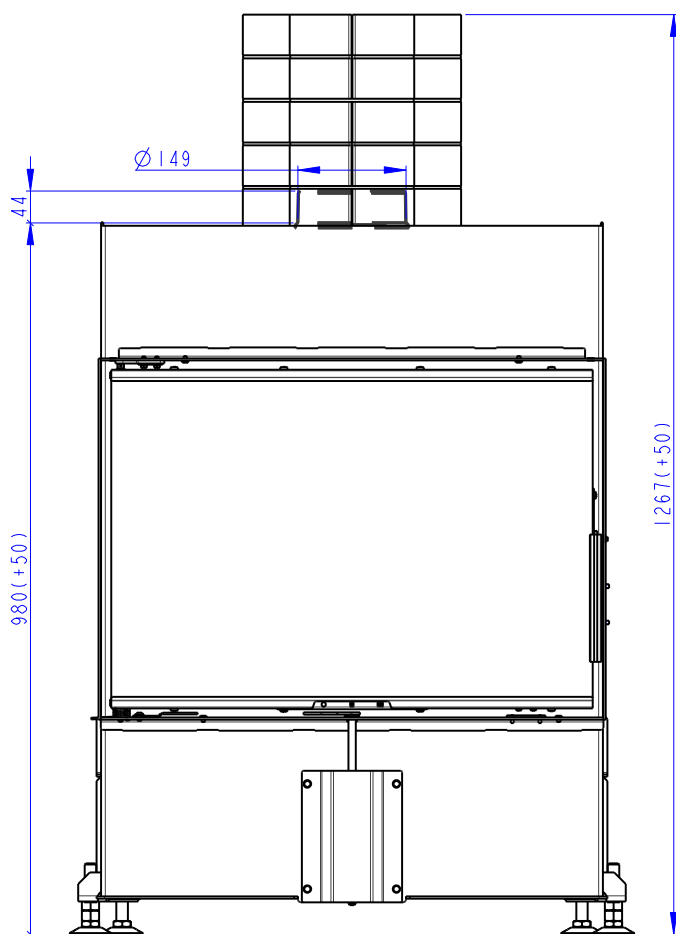
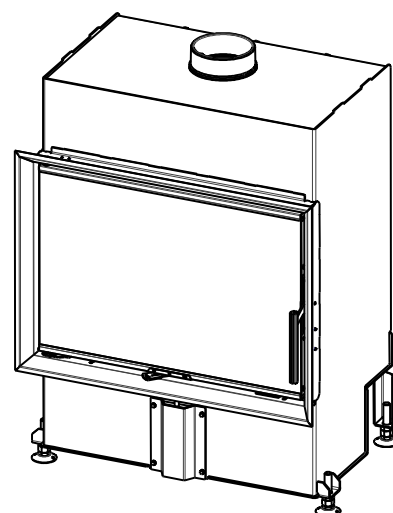
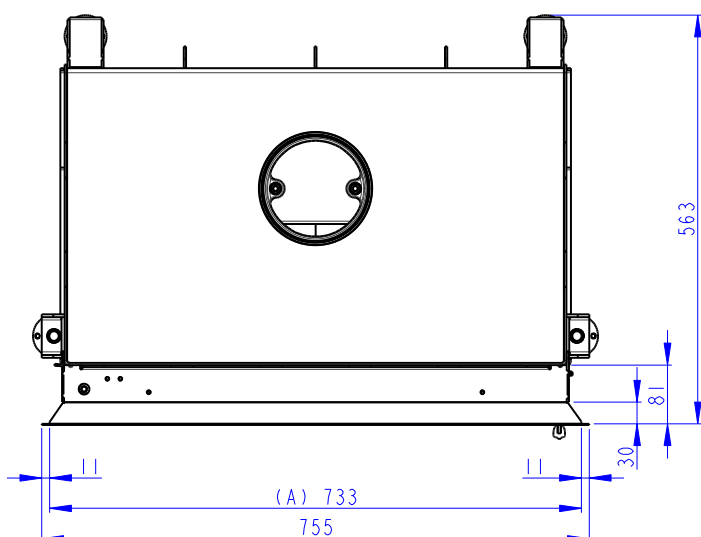
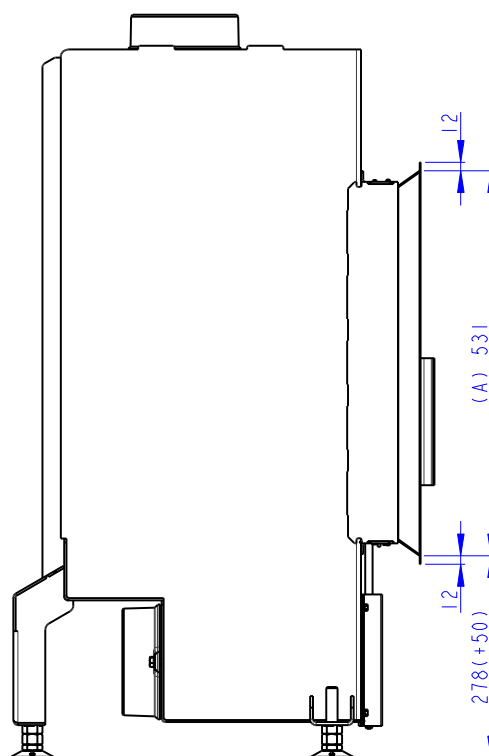
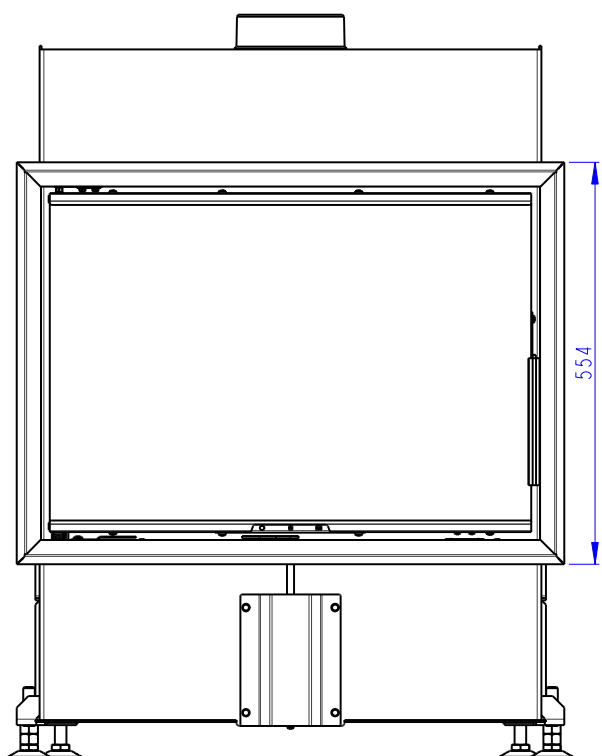

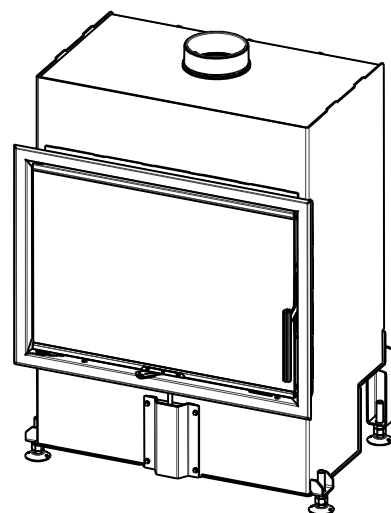
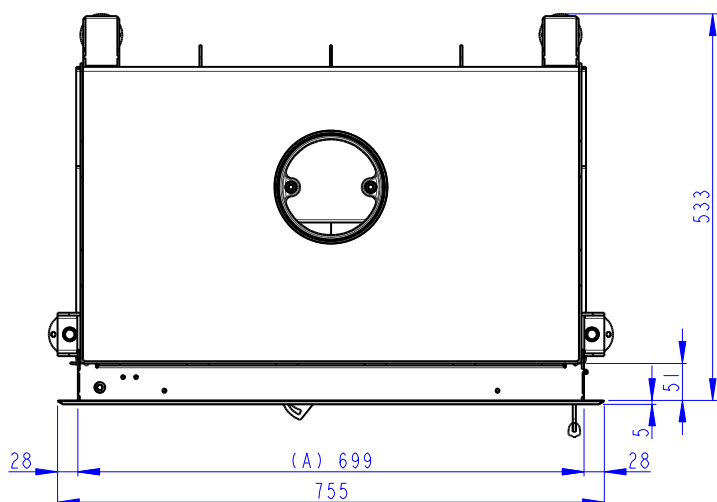
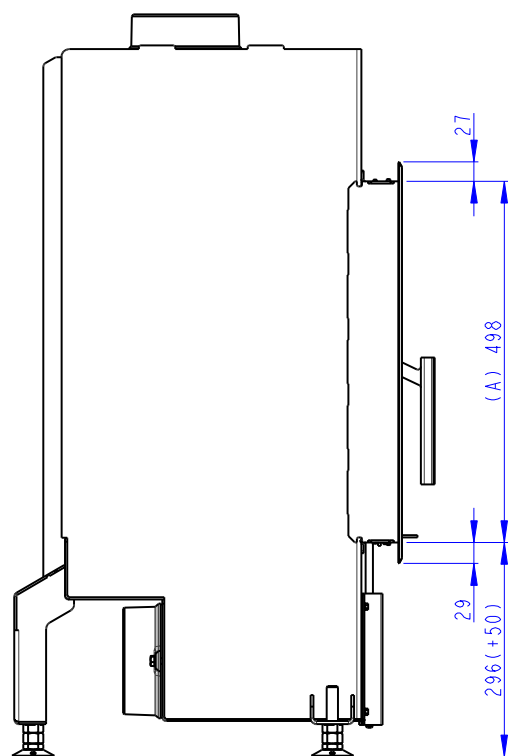
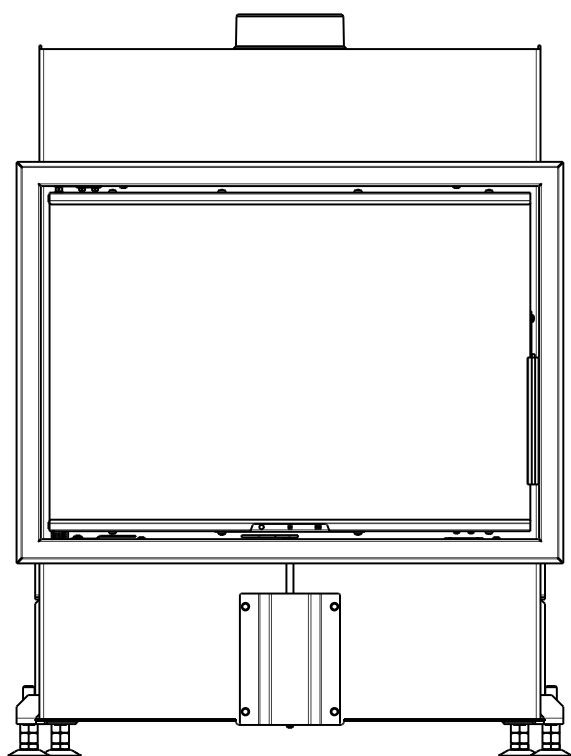

**Declared qualities stated**

 Harmonised technical specification ✓ EN 16510-1 ed.2:2023 | EN 16510-2-2:2022 ✓ Ecodesign ✓ DIN+ ✓ BlmSchV2 ✓ 15a B-VG 2015

Classification of appliance	Type BE		
		Nominal heat output (nom)	Part load heat output (part)
Energy efficiency	$\eta_{nom}   \eta_{part}$	80	---
Seasonal space heating energy efficiency at nominal heat output	$\eta_{s,nom}   \eta_{s,part}$	70	---
Energy Efficiency Index	EEI	106	
Energy label		A	
Fuel		Wood logs	
Fuel length		250-400	
Average fuel consumption		3,30	---
Allowed fuel dose		4,3	
Fuel supply interval		1 hour	
Amount of combustion air		41,8	
Nominal heat output	$P_{nom}   P_{part}$	11,0	---
Hot-water exchanger nominal heat output	$P_{Wnom}   P_{Wpart}$	---	---
Maximum water operating pressure	$P_W$	---	
Dry flue gas mass flow rate	$\Phi_{f,g,nom}   \Phi_{f,g,part}$	8,7	---
Average flue gas temperature		286	---
Flue gas outlet temperature	$T_{s,nom}   T_{s,part}$	343	---
Flue draught	$P_{nom}   P_{part}$	12	---
Chimney temperature class		T400	
Connection to the common chimney		Yes	
Storage of fuel in the wood shed area		No	
Maximum warming of the wood in the wood shed		---	
Dust O <sub>2</sub> = 13 %	$PM_{nom}   PM_{part}$	22	---
Emissions of gases of combustion (CO in the flue gases at O <sub>2</sub> = 13 %)	$CO_{nom}   CO_{part}$	0,0547 684	---
OGC O <sub>2</sub> = 13 %	$OGC_{nom}   OGC_{part}$	48	---
NO <sub>x</sub> O <sub>2</sub> = 13 %	$NO_{x,nom}   NO_{x,part}$	101	---
Automatic regulation unit of burning		---	---
Electricity consumption in standby mode	$e_{lsb}$	---	
Electricity consumption	$e_{l,max}   e_{l,min}$	---	---
Standing air loss	$V_h$	---	
Intermittent operation   Continuous operation	INT   CON	INT	

**Basic technical data**

Principal dimensions (Height   Width   Length)	H   W   L	1024   779   533	mm
Combustion chamber dimensions	H   W   L	385   608   328	mm
Fireplace door dimensions	H   W   L	467   664   ---	mm
Axis height of the rear (side) outlet		---	mm
Volume of hot-water exchanger		---	l
Flue diameter		150	mm
Diameter of flue throat	$d_{out}$	150	mm
Diameter of external air connection		150	mm
Maximum length (pipe) of external air intake		6000	mm
Weight	m	167	kg

## Heat capacity

### minimum size of the room of appliance installation

Insulation of the house – very good (20 W/m <sup>3</sup> )	e.g. new, insulated house / permanently inhabited	320	m <sup>3</sup>
Insulation of the house – good (22,5 W/m <sup>3</sup> )		284	m <sup>3</sup>
Insulation of the house – middle (32 W/m <sup>3</sup> )		200	m <sup>3</sup>
Insulation of the house – bad (45 W/m <sup>3</sup> )		142	m <sup>3</sup>
Insulation of the house – very bad (50 W/m <sup>3</sup> )	e.g. old, uninsulated house / cottage / chalet	128	m <sup>3</sup>

## Distances from flammable materials

### Note

Back	$d_R$		0	mm	
Front	$d_P$   $d_{P1}$		1400	---	mm
Front to the floor	$d_F$   $d_{F1}$		480	---	mm
Side	$d_S$   $d_{S1}$	*	420	---	mm
Side – niche	$d_{S2}$		---		mm
Side – location 45°	$d_{S3}$		---		mm
Side radiation	$d_L$   $d_{L1}$		430	---	mm
From the floor	$d_B$	**	100		mm
From the ceiling	$d_C$		500		mm
From the back and side edge of the fireplace insert to the inside of the insulation	$d_{S4}$	*	120		mm

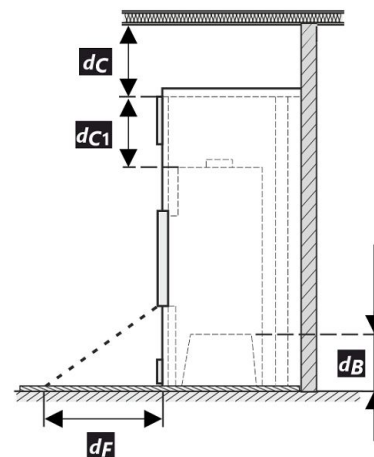
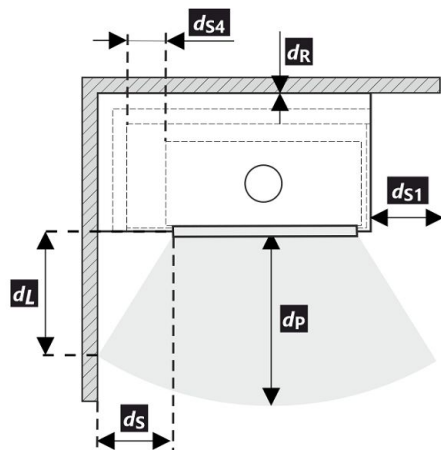

All local regulations, including regulations relating to national and European standards, must be observed during the installation and operation of the product.

In case 65 K is not superseded due to radiation on the floor in front and/or on the side walls,  $d_F$  and/or  $d_L$  are 0 mm.

- \* If the distance from the door glass to the combustible side wall is  $d_S < 420$  mm and must not be  $d_{S4} < 120$  mm, this wall must be protected by a SILCA 250 (SILCA® 250SB, thickness 2x50 mm) or can be replaced by an adequate substitute.
- \*\* If the distance of the bottom of the fireplace insert is from the combustible floor  $d_B < 100$  mm, while it must not be  $d_B < 100$  mm, the combustible floor must be protected from inserts by a SILCA 250 (SILCA® 250SB, thickness 40 mm) or can be replaced by an adequate substitute.

Legend	Note	Description	Material	Dimension
1		Appliance	179H 0000 004	
2		Flue gas outlet	metal	DN150
3		Insulation of the flue gas connection		
4		Mineral insulation		
5		Convection air space around the appliance		
6		Protective insulation of walls	SILCA 250	2x50 mm
6A		Protective ceiling insulation	SILCA 250	80 mm
7		Protective wall	hollow burnt brick	100 mm
8		Combustible wall		

<b>9</b>		Concrete slab	
<b>10</b>		Combustible floor	
<b>11</b>		Decorative / ornamental beam	
<b>12</b>		Beam with ventilation air gap	
<b>13</b>		Convection air inlet	800 cm <sup>2</sup>
<b>14</b>		Convection air outlet	1000 cm <sup>2</sup>
<b>15</b>		Lining	SILCA 250 40 mm
<b>16</b>		Support frame	
<b>17</b>		Combustible ceiling	
<b>18</b>	<b>**</b>	Protective insulation board for combustible floors	SILCA 250 40 mm
<b>19</b>		Combustion air regulation	
<b>20</b>		Sheet metal cover if mineral wool is used	
<b>21</b>		If necessary, a floor protection plate under the appliance	
<b>d<sub>c</sub></b>		From the top of the exhaust vent to the combustible ceiling	500 mm
<b>d<sub>c1</sub></b>		– From the top of the fireplace insert to the underside of the ceiling insulation – In the case of an installed heat exchanger from the top edge of the heat exchanger to the underside of the ceiling insulation	300 mm --- mm
<b>d<sub>s4</sub></b>	<b>*</b>	From the back and side edge of the fireplace insert to the inside of the insulation	120 mm
<b>d<sub>ss</sub></b>		From the front edge of the fireplace insert to the inside of the insulation	10 mm
<b>d<sub>B</sub></b>	<b>**</b>	From the bottom of the fireplace insert to the fireproof floor	100 mm

**Caution:** Fire protection / insulation boards SILCA® 250SB can be replaced by a suitable nonflammable material with a thermal conductivity ( $\lambda$ )  $\leq 1,1 \text{ W}\cdot\text{m}^{-1}\cdot\text{K}^{-1}$ .

Protective wall – hollow burnt brick (thickness 100 mm) can be replaced by a suitable nonflammable material with a thermal conductivity ( $\lambda$ )  $\leq 0,36 \text{ W}\cdot\text{m}^{-1}\cdot\text{K}^{-1}$ .

